

Bottom view

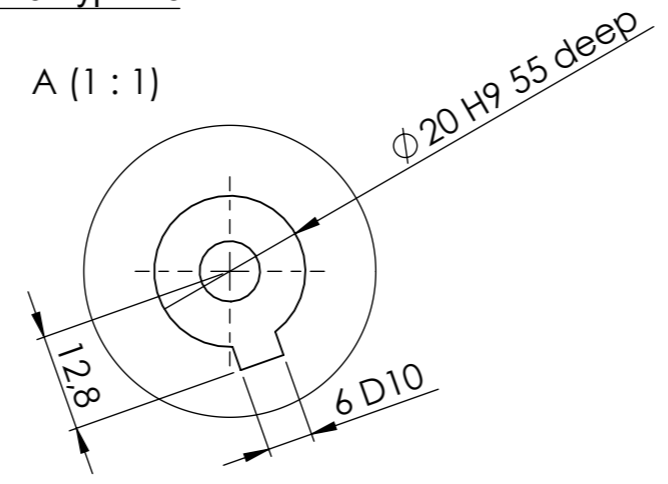

Top view
1:2

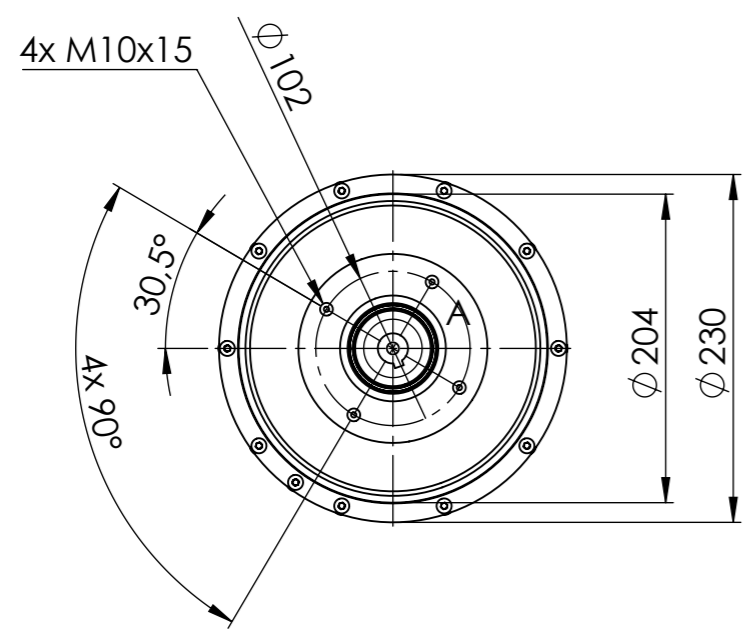

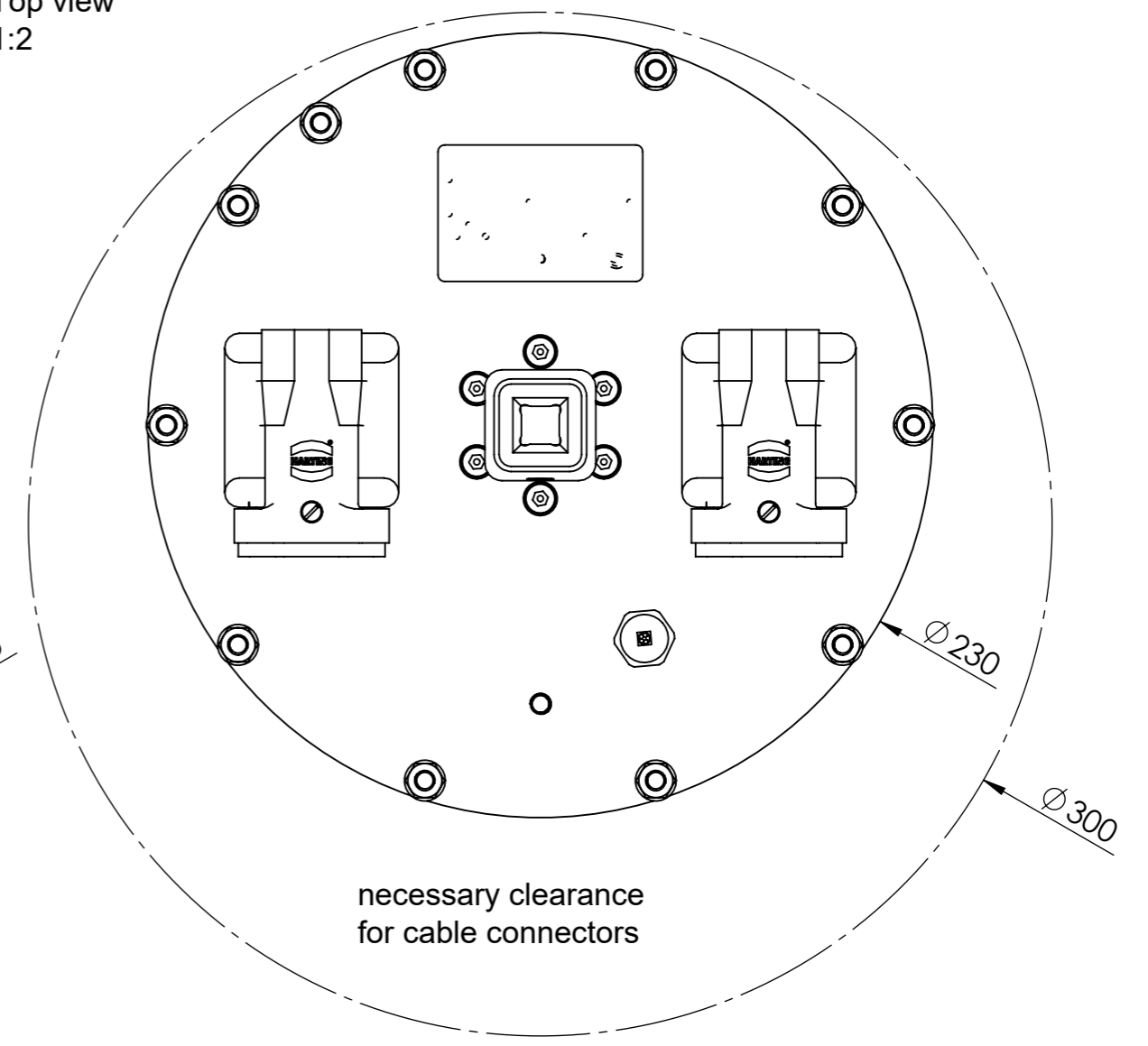

Protection class according to DIN EN 60529: IP 68 2m

Mounting position: square-end facing up

Installation depth: max. 300mm between surface level and top of actuator square-end, preferably 150mm (mind size of manhole cover)

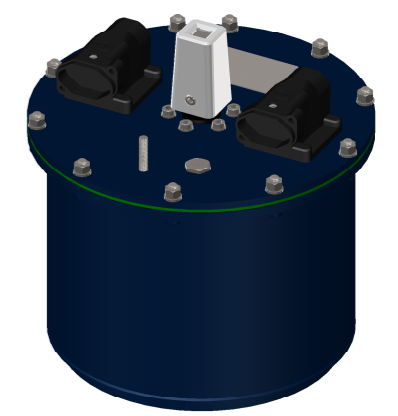
Servicing clearance: central clearance on top with respect to actuator casing, min D = 250mm



1	new			02.09.2020	Bohle
Index	Change History			Date	Name
Title				 S antriebe GmbH Antriebstechnik für Armaturen	
Material			Status	Revision	Tolerances
miscellaneous					DIN ISO 2768-mK
Weight (g)	Scale	Date	Drawn by	Checked by	Format Index DWG No
14500	1:5	02.09.2020	D. Bohle	D. Olszewski	A3 1 08.0033