

> 3S AIG XS (Smart Valve Key) Grid operation of tomorrow

DIGITAL DOCUMENTATION

- >> Condition monitoring: number of turns, torque, valve tightness
- >> WLAN interface + App
- >> Condition based maintenance
- >> Maintenance instead of replacement

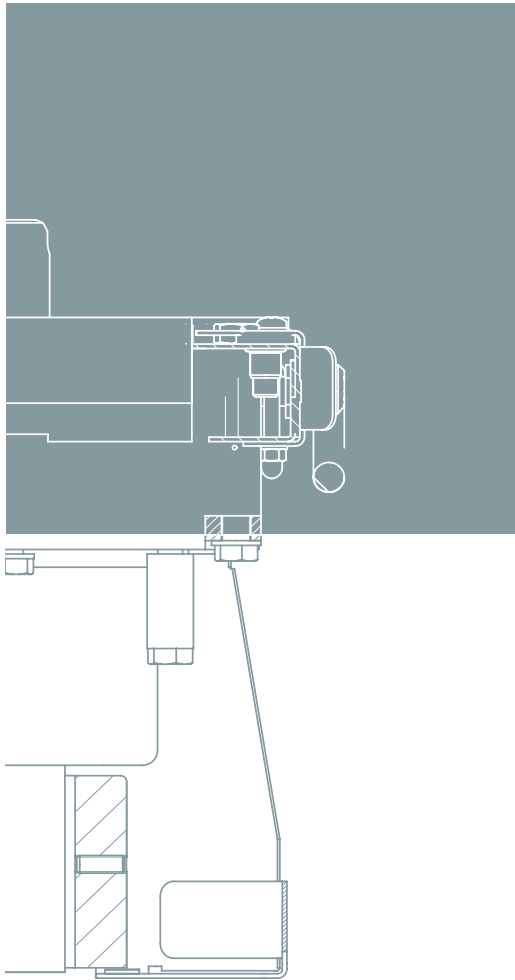

Maintenance

Functional inspection Service Repair

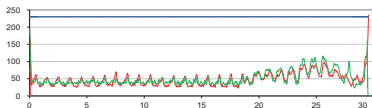
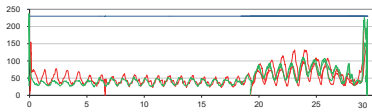
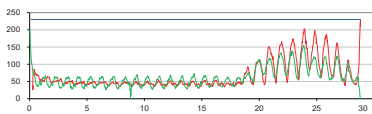

SYSTEM
BERLINER
KAPPE®



> 3S AIG XS

> Technical data

- >> 5.3 kg (11.7 lbs.) light and therefore operable by one person
- >> Maximum torque of 900 Nm, 1,800 Nm with torque booster
- >> Digital interface for importing master file data of valves (work scheduling) and for exporting measured status data
- >> Efficient external lithium-ion battery
- >> Individual torque limiting according to valve specifications
- >> Automatic functionality for easy and comparable maintenance efforts
- >> Compatible with the System Berliner Kappe

> Models

Model	Torque	Rotation speed
	max.	max.
XS-900	900	20
XS-450	450	43

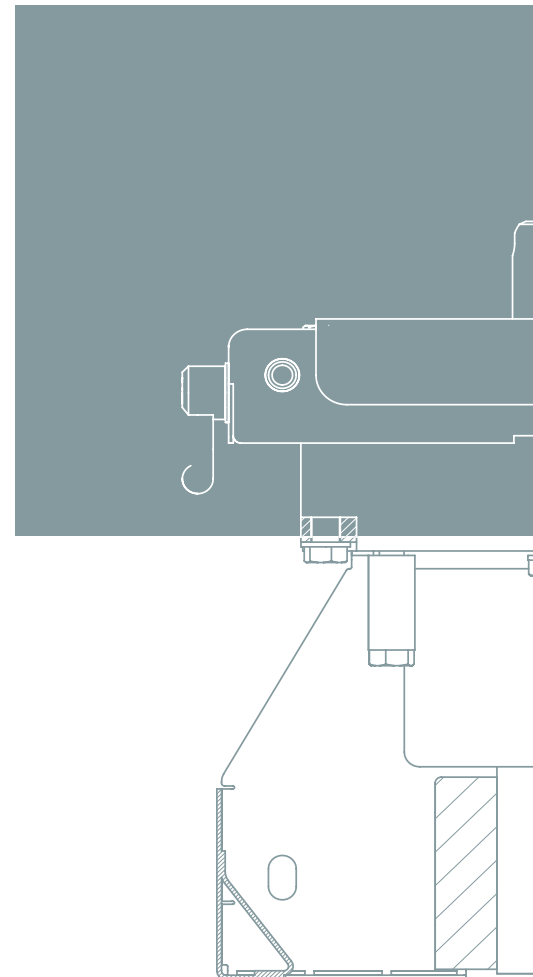

Water gate valve DN 300

Most likely caused by incrustations, this valve was set to be replaced. After increasing torques multiple times, the breakaway torque of 700 Nm was reached, and it could be closed. After multiple turns opening and closing, the valve could reach the maximum number of turns and not be closed any further. The reference curve shows clear improvement and a successful maintenance.

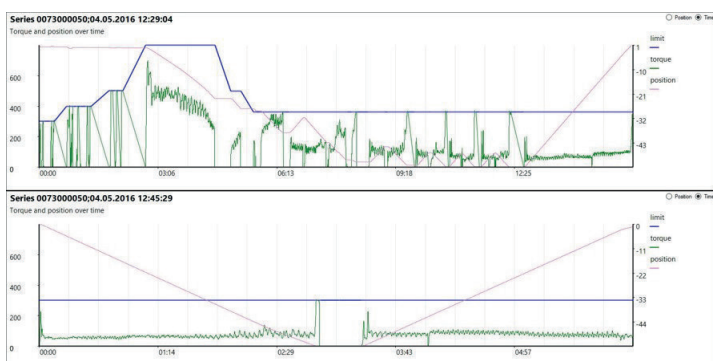

3S Antriebe GmbH
Schichauweg 52
12307 Berlin

Tel +49(30)7007764-0
Fax +49(30)7007764-20
info@3S-Antriebe.de

www.3S-Antriebe.de